

SY215C

SANY

Quality Changes the World



PRECISE POWER

CONSISTENTLY STRONG. REMARKABLY VERSATILE.

CONSTRUCTION MACHINERY



CRAWLER EXCAVATOR
SY215C

Engine
CUMMINS QSB6.7
Rated power
129 kW / 2200 rpm
Bucket capacity
0.93 m³
Operating mass
23550 kg

SANY

For challenging tasks, you need a first-class partner

Quality comes from experience. And from new ideas. This is why we combine these two crucial factors at SANY. This is because we are one of the leading producers, having sold more than **450 000** excavators **worldwide**. This means that you can always rely on sophisticated products that have been tried and tested in practice. An impressive **5–7%** of our annual turnover is dedicated to research and development. This is why we give you not only our word, but also our extraordinary **five-year warranty** as a guarantee of how powerful and robust our products are.

450 000

EXCAVATORS SOLD
WORLDWIDE

5–7%

TURNOVER FOR RESEARCH
AND DEVELOPMENT

FIVE-YEAR WARRANTY *

Quality Changes the World



* Applicable in certain markets, please check with your local dealer.



SY215C HARD FACTS

Max. bucket digging force
143 kN (ISO)

Max. arm digging force
115 kN (ISO)

Swingspeed
11 rpm

Max. travel speed
5.4 km/h

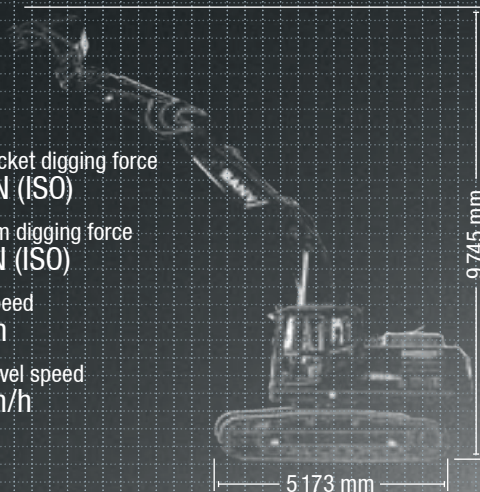



THE SPECIALIST WHEN IT COMES TO VERSATILITY

With the SANY SY215C crawler excavator, you get more done. No matter where used – it applies its power with precision. This is because every detail is specifically designed for the tough conditions on construction sites. This excavator is a real all-rounder and a specialist in every discipline, from quick loading to precise digging and powerful demolition work.

What particularly sets it apart is its ability to control its tremendous power with great precision – for maximum productivity and therefore a fast return on investment.

TOP PROPERTIES

ECONOMY

IT IS AS LOW IN CONSUMPTION AS IT IS POWERFUL IN PERFORMANCE

The highly efficient engine with common rail technology guarantees excellent performance. Four different operating modes for the various operating conditions precisely adjust the engine and hydraulic power to the requirements. This improves the excavator's response behaviour. Fuel consumption and emissions, which were already very low, have been

further reduced to meet the latest Stage V emissions standard. Another benefit ensuring higher efficiency whilst reducing component costs is the fact that the machine still operates without an exhaust gas recirculation system.

QUALITY

Durable and robust – the SY215C can be used whenever the going gets tough. This means that it must be able to withstand a great deal. No problem for the SY215C, as with its reinforced, **extremely robust undercarriage** and particularly clean, **robot-welded seams**, it is exactly the right excavator for hard day-to-day work on construction sites.

USER EXPERIENCE

Comfortable workstation – the cabin of the SY215C leaves nothing to be desired. All of the controls are within easy reach from the air-suspension seat which supports the driver's back. **Maintenance and service support** is also easy to reach: Thanks to the large and easily accessible service doors and clear layout of the most important components, this work is **quick and easy** to complete.

DIMENSIONS

Agile power – the SY215C works through its programme quickly and with great power. This excavator has great power reserves in its 23+ tonnes. The machine is mounted on a stable HD undercarriage so that it can be used to the full.



SAFETY

Safety as a production factor – it is only possible to work cost-effectively if you work safely. This is why the **large safety package** has everything included **as standard**, from LED working lights to the rotating beacon, and from the boom safety valve to the overload warning for lifting

COMPONENTS

High quality and tried-&-tested – the water-cooled Cummins diesel engine with common rail technology and AdBlue system guarantees **reliable performance**, even under tough working conditions. The complete package is rounded off by the finely tuned Kawasaki hydraulic system.

ECONOMY

Power and efficiency – the smart hydraulic control system adapts the pump power to the available engine power. This means **greater efficiency** and **lower fuel consumption**, thereby providing excellent **cost-effectiveness**.

ECONOMY

Cost-effectiveness thanks to maximum flexibility

Whether digging, loading, demolishing, transporting, hammering, or performing other tasks, the SANY SY215C tackles a wide range of tasks without compromise – and without long changeover or waiting times. The pre-installed quick-coupler line means that many attachment devices can be fitted. Various working modes ensure optimum efficiency at all times.



ECONOMY

EVERYTHING IN VIEW, EVERYTHING UNDER CONTROL

To enable efficient work at the construction site, you can, for example, save the required working pressures and oil flow for the two proportional auxiliary lines for up to five attachment devices in each category. Simply enter the name of the attachment in the large, high-resolution 10" touch display and assign the required value to the tool. This makes changing attachments on the job site quick and uncomplicated - time and costs can be significantly reduced as a result. In addition, the large touch display with its simple menu allows intuitive navigation and monitoring of all important parameters.



ECONOMY

Changed well

The hydraulic quick-coupler line is already included ex-works as standard and is incorporated into the operating concept. The powerful hydraulic system is factory-equipped with numerous functions that help the crawler excavator achieve maximum flexibility. In addition, one of the machine's new features makes changing tools even easier and quicker. When switching from hammer to shear hydraulics, the hammer valve is switched by pressing the key on the display. The attachment devices can therefore be switched completely from the cab, in conjunction with the respective quick coupler systems.



Absolute reliability – for peace of mind!

SANY's five-year warranty* gives you the assurance that you can fully count on your equipment.

* With participating partners

EFFICIENCY, COST-EFFECTIVENESS AND USER EXPERIENCE



USER EXPERIENCE

THE NEW COMFORT ZONE

For drivers to fully concentrate on their work, they first need to be sitting comfortably. The individually adjustable, air-suspension seat offers a comfortable workstation from which all of the controls are within easy reach. At the forefront, alongside the ergonomic controls, is the 10" touch display. This displays razor-sharp images from both cameras, and has intuitive controls which allow all relevant machine parameters to be set with great ease, in all common European languages. Naturally, the consoles move up and down with the seat, thus providing the best possible protection for the operator even in the event of impacts. The flat design of the engine cover allows a view of the rear working area.

The automatic climate control system which provides pleasant temperatures even in the summer, the powerful heating, and the radio with an additional USB port for the driver's own audio devices all comes as standard, as do the large storage compartments for everything the driver needs close to hand.

COMPONENTS

Improved performance thanks to optimised hydraulics

The position-controlled hydraulic system adjusts the required pressure and oil flow according to requirements. The powerful, variable piston pumps reach a flow rate of 2 x 241 l/min and therefore achieve a very high level of efficiency at a low engine speed.



Our highlights – the added benefits SANY offers you:

- + Large, high-resolution 10" touch display
- + 2 cameras
- + Seat with adjustable consoles
- + 5 different attachments per category programmable (name, pressure, oil flow)
- + 2 proportional control circuits as standard
- + Comfortable switching of hammer/shear hydraulics

USER EXPERIENCE

Minimising maintenance times and maximising operating times

All serviceable components are easily accessible. This means that any maintenance and service support can be carried out efficiently and safely, reducing unproductive downtime and increasing machine availability.

Daily routine checks in particular can be carried out quickly, easily and safely by hand, because handrails, non-slip treads. A lot of maintenance tasks, such as cleaning the air filter, are already possible from the ground.



QUALITY

A very stable foundation

The machines have a great deal of work to do during their tough day-to-day work on construction sites. This is why – from the design stage, to selecting the materials used, quality and conducting the final checks – all excavators by SANY are designed to be robust. For instance, all welded seams are computer-controlled by robots – this maximum precision ensures stability and reliability.

SAFETY

Best visibility even in poor lighting conditions

Good visibility is required for precise, quick work. In the worst-case scenario, the SY215C itself will provide sufficient lighting. The operating area is illuminated by two LED roof working lights, two LED working lights on the boom, one in the upper structure and an LED working light facing backwards. The high-quality LED working lights not only stand out thanks to their particularly good illumination, but also due to their low power consumption and extreme durability, while also being virtually maintenance-free. For enhanced safety, two cameras are also provided to show all poorly visible areas of the machine. With a single tap, the images can be combined or shown individually on the high-resolution display.



TECHNICAL SPECIFICATIONS

MOTOR

Model	CUMMINS QSB6.7
Typ	Water-cooled, 6 cylinder, with commonrail and Adblue
Exhaust emissions	Stage V
Rated power	129 kW / 2 200 rpm
Max. torque	881 Nm / 1300 rpm
Displacement	6 700 ccm
Batteries	2 × 12 V / 120 Ah

HYDRAULIC SYSTEM

Mainpump	2 x variable-piston-pump with electronic positive control
Max. oilflow	2 × 241 l/min
Travelmotor	Variable displacement axial piston motor
Swingmotor	Axial piston motor
Max. oilflow (AUX1)	400 l/min

RELIEF VALVE SETTINGS

Implement circuit	343 bar
Power boost	373 bar
Swing circuit	275 bar
Travle circuit	343 bar
Pilot pressure	39 bar

SERVICE REFILL CAPACITIES

Fuel tank	370 l
Engine coolant	27.6 l
Engine oil	27 l
Drive (per side)	5.5 l
Adblue	45 l
Hydraulic oil tank	200 l

PERFORMANCE

Swingspeed	11 rpm
Max. travel speed	High 5.4 km/h, slow 3.3 km/h
Max. travel force	191 kN
Gradeability	35°
Bucket capacity	0.93 m ³
Groundpressure	0.47 kg/cm ²
Bucket digging force ISO	143 kN
Arm digging force ISO	115 kN

UNDERCARRIAGE AND UPPER STRUCTURE

Boom length	5 700 mm
Arm length	2 925 mm
Bottomrollers	9
Toprollers	2
Rotation device	Planetary gear reducer driven by an axial piston motor, automatic hydraulic released slewing brake

OPERATING MASS

SY215C 23 550 kg

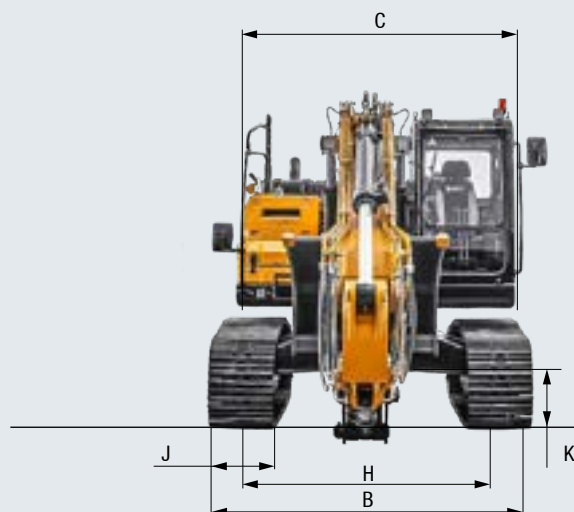

LIFTING CAPACITIES*

Load point height	Radius				Max. digging reach			
	3.0 m	4.5 m	6.0 m	7.5 m	Capacity		mm	
7.5 m kg			4232	4232	3449	3449	6200	
6.0 m kg			5360	5150	5290	5130	7300	
4.5 m kg			5900	5973	5380	5010	7980	
3.0 m kg	7499	7499	6570	6530	5690	4830	5380 4180 8330	
1.5 m kg	8954	8197	7360	6330	6170	4540	5630 3880 8400	
Ground line kg	7389	7389	9726	7832	7123	5265	5689 3890	3409 3409 8200
-1.5 m kg	11637	11637	9745	7710	7221	5161	5589 3851	3967 3730 7700
-3.0 m kg	12677	12677	9026	7778	6691	5160		5161 4407 6840
-4.5 m kg	9843	9843	7102	7102				5483 5483 5450

* at 600 mm track pads width

DIMENSIONS

A	Transport length	9635 mm
B	Transport width*	2980 mm
C	Overall width of upper structure	2753 mm
D	Height over cabin/ROPS	3255 mm
E	Height of Boom – transport	3090 mm
F	Overall length of crawler	5173 mm
G	Tail length	2950 mm
H	Track gauge	2380 mm
I	Track height	923 mm
J	Track pads width	600 mm 700 mm 800 mm
K	Min. ground clearance	468 mm
L	Counterweigh clearance	1090 mm
M	Engine cover height	2630 mm
N	Tail swing radius	2890 mm
O	Center distance of tumblers	3640 mm

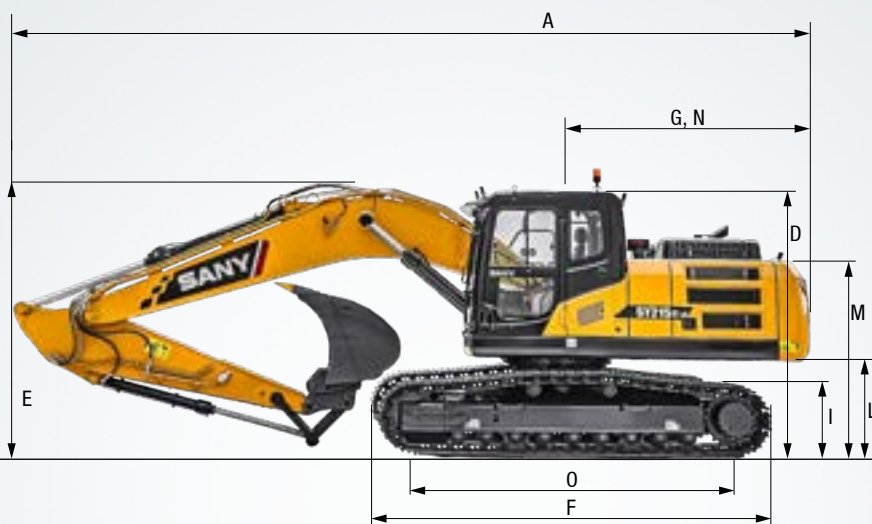

* at 600 mm track pads width

WORKING AREA

A	Max. digging reach	9745 mm
B	Max. digging depth	6450 mm
C	Max. digging Height	9470 mm
D	Max. dumping height	6735 mm
E	Min. dumping height	2470 mm
F	Max. vertical digging depth	6225 mm
G	Overall height over arm by min. swing radius	7600 mm
H	Min. swing radius	3662 mm

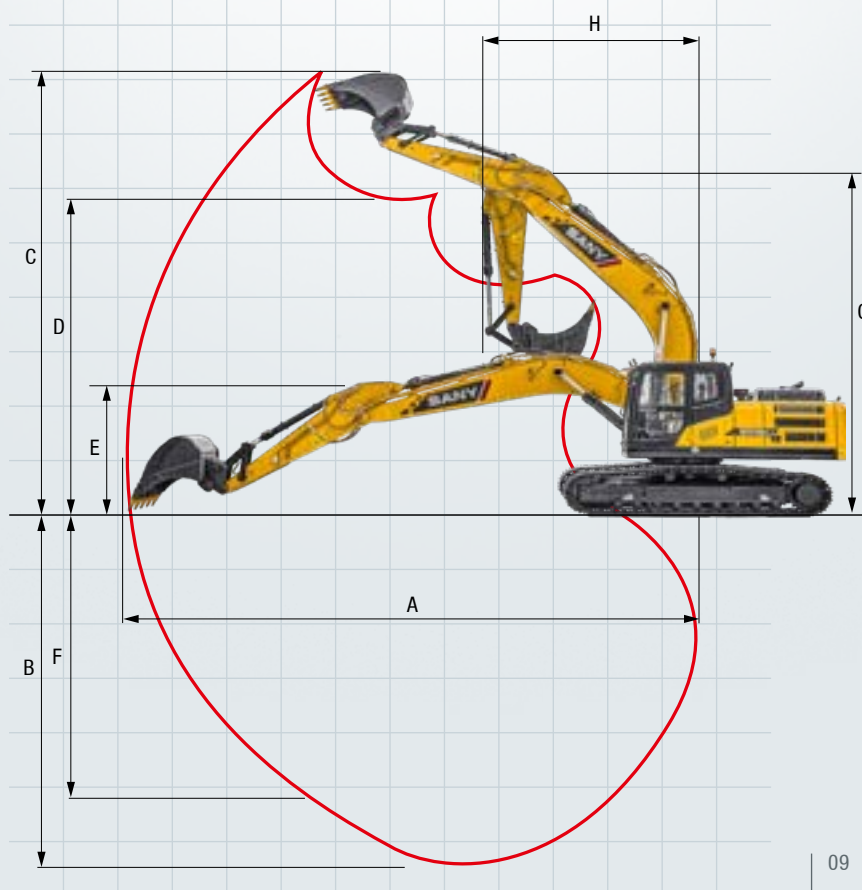

Versatile power

With the SANY SY215C, you do not need to worry about additional extra options. Everything you need for easy, comfortable work is included as standard.



OPERATORS COMFORT / CABINE

Heater	●
Automatic air conditioning C/H*	●
Radio and speaker	●
Armrests (adjustable)	●
12v outlets	●
USB port (music)	●
Airsuspension seat	●
Heated seat	●
Wiper	●
AUX 1 on joystick	●
AUX 2 on joystick	●
Sky light openable	●
Integrated cooling box	●
10" touch display	●

WORKING EQUIPMENT

Boom and arm load holding valves with overload indicator	●
Double acting circuit for hydraulic quick coupler with piping	●
Breaker&Shear line proportional on joystick with piping	●
Rotation line proportional on joystick with piping	●
Flow adjustment for attachments	●
Pressure adjustment for attachments	●

UNDERCARRIAGE

Steel tracks 600	●
Holes/loops for fixing	●

Standard equipment ● Special option ●

The standard and special options differ depending on the country in which the crawler excavator is delivered. If you have any questions, please contact your dealer directly.

* The air conditioner contains fluorinated greenhouse gases: Refrigerant type: HFC-134a, Global warming potential: 1 430, Quantity: 0.9 kg, CO₂e: 1.29 t

WORKING LIGHTS

Lights – front (LED)	●
Lights – boom (LED)	●
Lights – platform (LED)	●
Lights – back (LED)	●

ENGINE/ENGINE COMPARTMENT

Auto idle	●
Fuel pump	●
SCR	●
DPF	●
DOC	●

HYDRAULIC SYSTEM

Swing brake	●
2 speed travel	●
Piping for additional hydraulic function AUX 1	●
Piping for additional hydraulic function AUX 2	●
Hydr. Pre-pressure operating joysticks	●

SAFETY

Battery master switch	●
Travel Alarm	●
Warning beacon	●
Rear camera	●
Camera on right side	●
Handrails	●
Lockable hoods	●
Lockablge fuel cap	●

Parts supply – quick and reliable

With the purchase of a SANY crawler excavator you have made an investment in the future. Fast availability of spare parts is your guarantee of minimal downtimes and failure times.



A SERVICE YOU CAN RELY ON

Just as we do with our excavators, we also demand high quality and reliability of our service products. This underlines our equipment's performance in terms of their durability and their excellent price-performance ratio. After all, maintenance is crucial

for efficiency, cost-effectiveness and safety. Your SANY dealer is happy to help you with a comprehensive range of services to ensure that your machine continues operating efficiently in the long term.

SANY – flexible, fast and always there for you

Rapid assistance, tailored advice and a reliable supply of original parts – that is what we mean by a premium service.



The added benefits SANY offers you:

- + Fast supply thanks to the central warehouse near Cologne
- + More than 15,000 spare parts to make your machine highly reliable
- + Expert knowledge for optimal supply for your machine
- + Thanks to SANY's special training programme, our dealers are always kept up-to-date so that they can face all technical challenges.

Detailed information in black and white

Handbooks and documents are available for all SANY crawler excavators, and these can help you with operation, maintenance, servicing and repairs. These include operating and maintenance instructions and technical specifications.



THE ALLROUNDER THAT PICKS UP EVERYTHING

The SANY SY215C is a powerful all-rounder which combines flexibility and power. It can therefore perform various tasks in a wide range of applications and its robust design means that it is comfortable even with difficult tasks and tough environments.



SAFETY AS A PRODUCTION FACTOR

The cleverly designed cab structure allows an unobstructed view of the working area, and the **two cameras that are fitted as standard** provide a good overview. The LED lighting system is essential for long working days. Alongside this, optimised access to all maintenance points ensures maximum safety at all times.

COMFORTABLE WORKSTATION

You know there are good **ergonomics** when you can still concentrate on your work after several hours. No problem in the cockpit of the SY215C because the seat and controls have been **designed for practical requirements**. All the machine settings can be configured using the high-resolution 10" touch screen which is easy and intuitive to operate.

HIGH QUALITY AND TRIED-AND-TESTED

With its maximum torque of 881 Nm at 1300 rpm, the very strong **Cummins Stage V, six-cylinder engine** brings an incredible amount of power.

DURABLE AND ROBUST

The SY215C has to endure a lot in its tough daily construction site work. But it is well prepared for this. High-quality materials and meticulous machining provide the foundation for its long service life: For example, the **reinforced undercarriage** and **precise, welded seams**. Maximum stability designed to last many decades is also guaranteed by the **continuous plate on the underside of the boom**.

AGILE POWER

The SY215C works through its programme quickly and yet powerfully. This excavator has huge **power reserves** in its 23+ tonnes. The machine is mounted on a **stable HD undercarriage** so that it can be fully utilised.

EFFICIENCY AND POWER

The **smart hydraulic control system** adapts the pump power to the available engine power. This reduces fuel consumption, engine wear and exhaust gas emissions.

The comprehensive standard functions of the hydraulic system make the machine perfect for virtually all tasks.

TECHNICAL HIGHLIGHTS

Engine	CUMMINS QSB6.7
Rated power	129 kW / 2 200 rpm
Max. torque	881 Nm / 1 300 rpm
Max. travel speed	5.4 km/h
Swingspeed	11 rpm
Mainpump	2 x variable-piston-pump with electronic positive control
Max. oilflow	2 x 241 l/min

Not all products are available in all markets. As part of our continuous improvement process, we reserve the right to modify specifications and designs without giving prior notice. The figures may contain additional options.

SANY

Quality Changes the World

SANY EUROPE GmbH

Sany Allee 1
D-50181 Bedburg
fon +49 2272 90531 100
fax +49 2272 90531 109
info@sanyeurope.com
www.sanyeurope.com